

POSIWIRE®
WS100M
Analog Output



APPLIED MEASUREMENTS LTD.
 3 Mercury House, Calleva Park, Aldermaston, Berkshire, RG7 8PN
 Tel: +44 (0) 1189 817339 | Web: www.appmeas.co.uk
 Fax: +44 (0) 1189 819121 | Email: info@appmeas.co.uk



Sensor for hostile environments and offshore applications

- Protection class IP68/IP69K
- Measurement ranges 0 ... 2000 mm to 0 ... 10000 mm
- Analog output

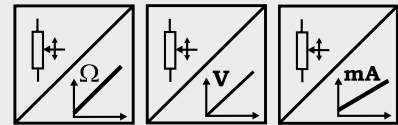

Specifications	Outputs	Potentiometer 1 kΩ Voltage 0 ... 10 V Current 4 ... 20 mA, 2 or 3 wire
	Resolution	Essentially infinite
	Linearity	Up to ±0.05 % f. s.
	Sensing device	Hybrid precision potentiometer
	Material	Stainless steel; cable: stainless steel
	Protection class	IP68/IP69K
	Connection	Cable output, standard length 2 m
EMC, temperature	Refer to output specification	

Order code WS100M



Model name

Measurement range (in mm)

2000 / 3500 / 7500 / 10000

Outputs

- R1K = Potentiometer 1 kΩ
- 10V = 0 ... 10 V signal conditioner
- 420A = 4 ... 20 mA signal conditioner (2 wire)
- 420T = 4 ... 20 mA signal conditioner (3 wire)

Linearity

L10 = ±0.10 % option: L05 = ±0.05 % L25 = ±0.25 %

Cable fixing

M4VA = M4 cable fixing

Connection

KAB2M = Cable output, standard length 2 m

Order example: WS100M - 7500 - 420T - L10 - M4VA - KAB2M

POSIWIRE®

WS100M

Analog Output

Outline drawing
WS100M-2000 / 3500

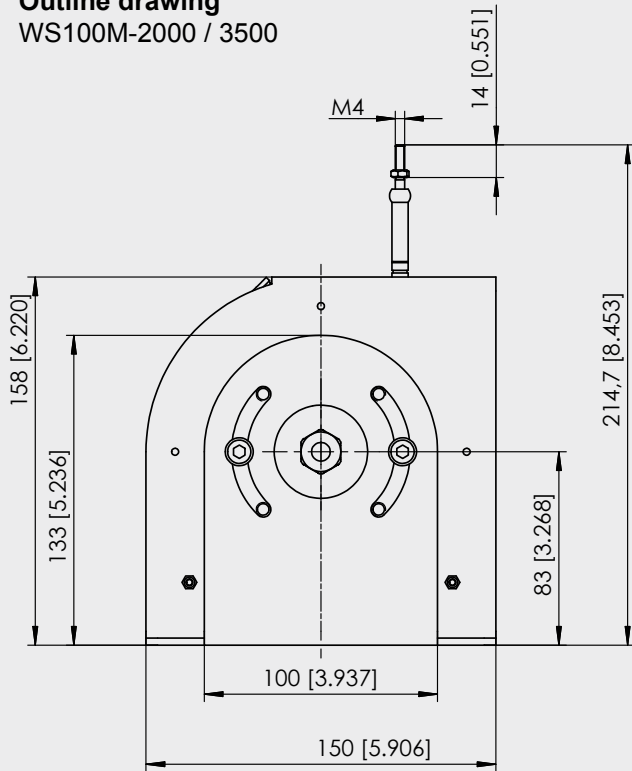

Measurement range 2000 mm

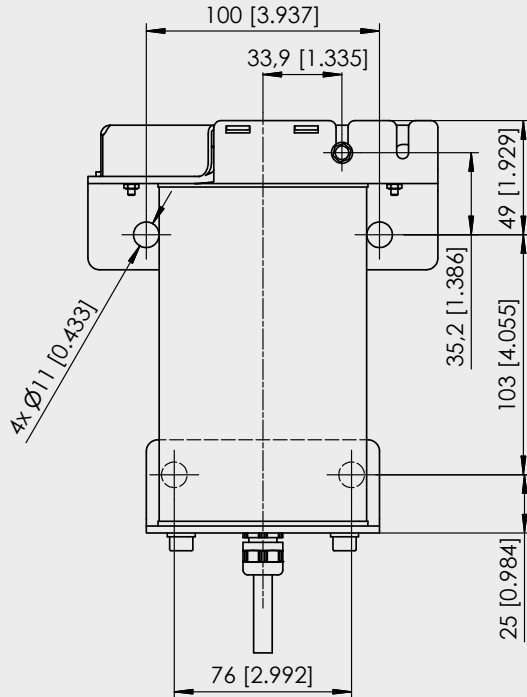

Dimensions in mm [inch]

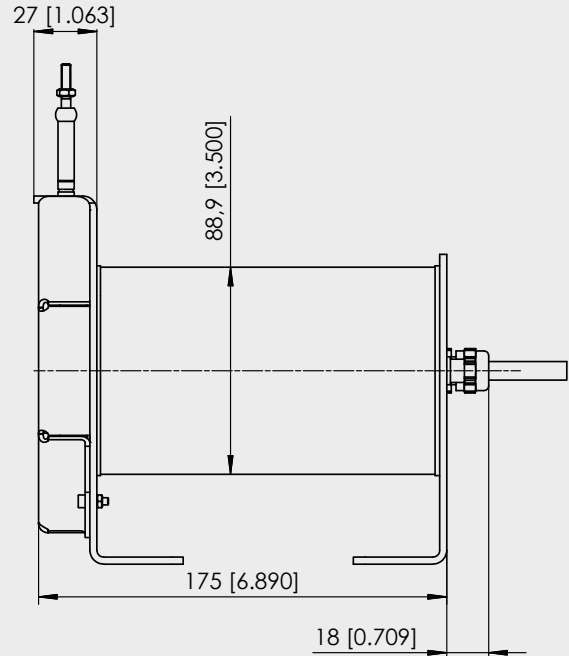

Measurement range 3500 mm

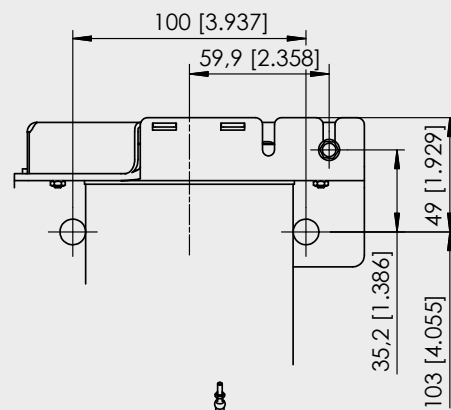

Dimensions informative only.
For guaranteed dimensions consult factory.

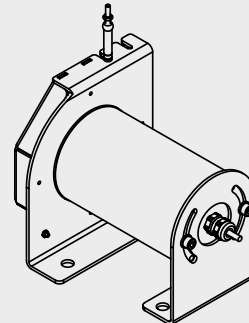

POSIWIRE®

WS100M

Analog Output

Outline drawing
WS100M-7500

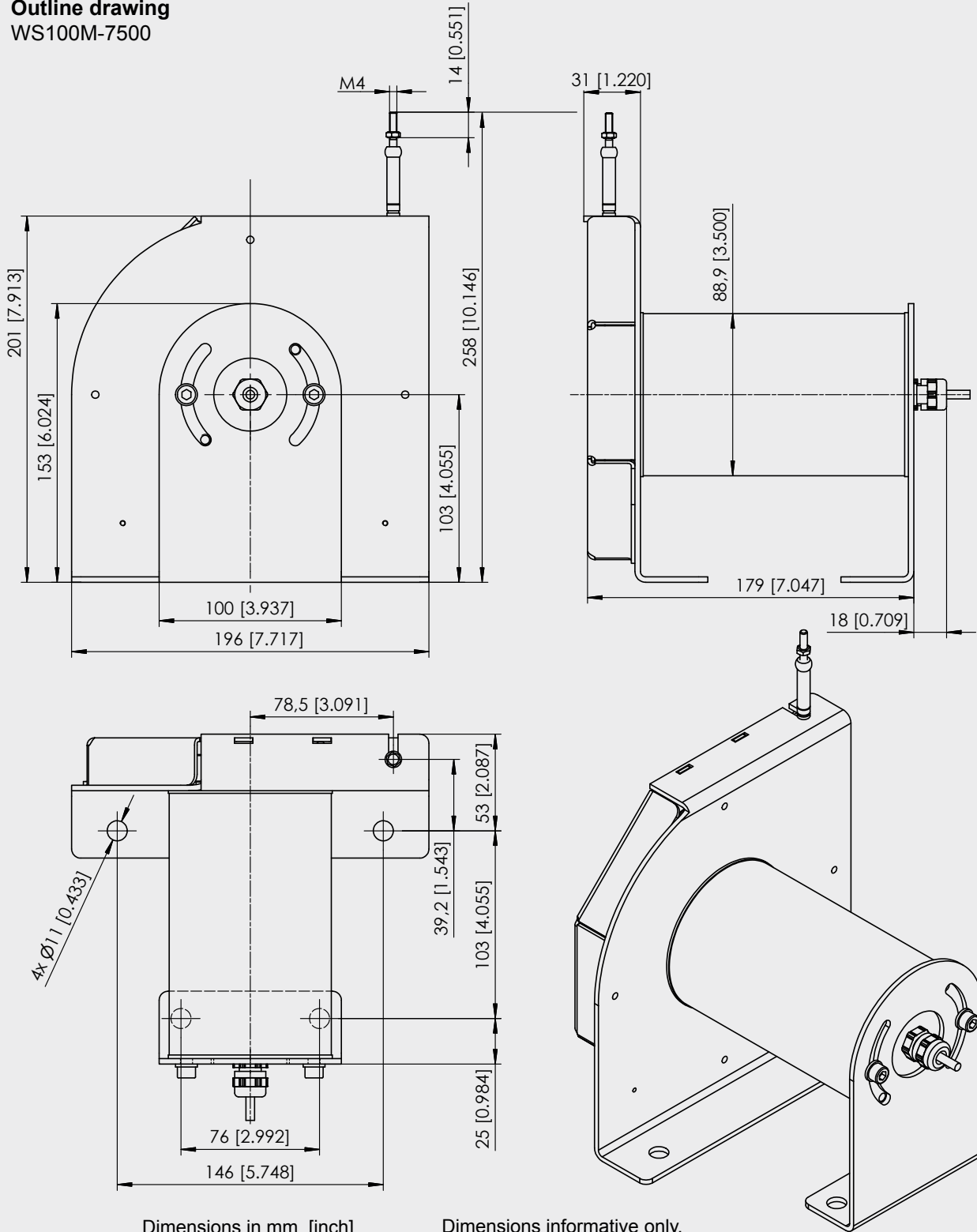

Dimensions in mm [inch]

Dimensions informative only.
For guaranteed dimensions consult factory.

POSIWIRE®
WS100M
Analog Output

Outline drawing
 WS100M-10000

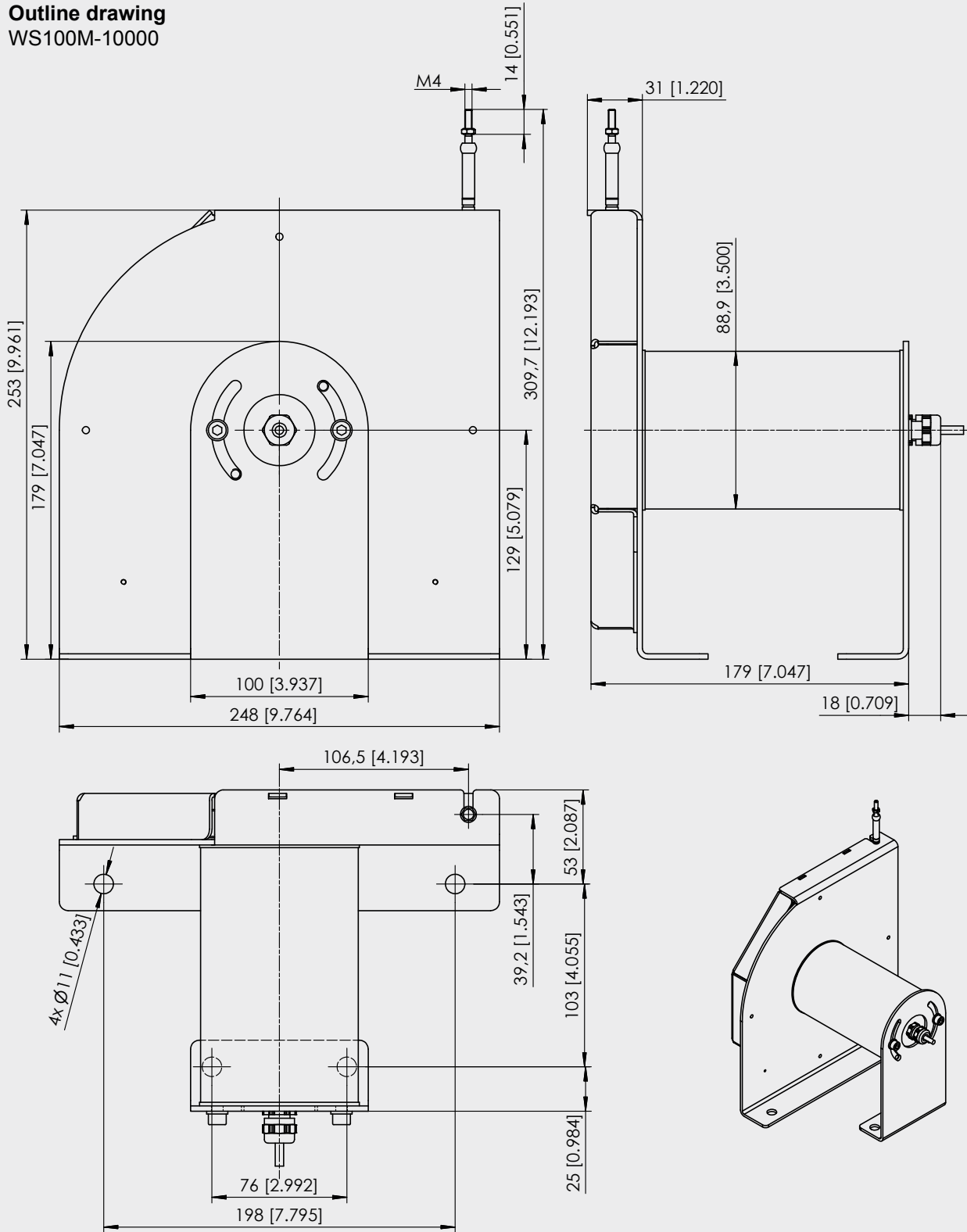

Dimensions in mm [inch]

Dimensions informative only.
 For guaranteed dimensions consult factory.

POSIWIRE®

R1K and 10V

Analog Output

Voltage divider R1K Potentiometer 	Excitation voltage	32 V DC max. at 1 kΩ (max. power 1 W)
	Potentiometer impedance	1 kΩ ±10 %
	Thermal coefficient	±25 x 10 ⁻⁶ / °C f.s.
	Sensitivity	Depends on the measuring range, individual sensitivity of the sensor is specified on the label
	Voltage divider utilization range	Approx. 3 % ... 97 %
	Operating temperature	-20 ... +85 °C

Output signals

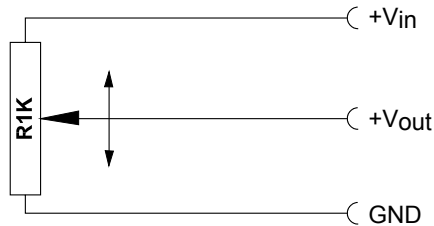

Note: The Potentiometer must be connected as a voltage divider. The input impedance of the following processing circuit should be 10 MΩ min.

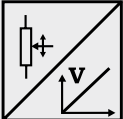
Signal conditioner 10V and 10V5 Voltage output 	Excitation voltage	18 ... 27 V DC non stabilized
	Excitation current	20 mA max.
	Output voltage	10V: 0 ... 10 V DC; 10V5: 0.5 ... 10 V DC
	Output current	2 mA max.
	Output load	> 5 kΩ
	Stability (temperature)	±50 x 10 ⁻⁶ / °C f.s.
	Protection	Reverse polarity, short circuit
	Output noise	0.5 mV _{RMS}
	Operating temperature	-20 ... +85 °C
	EMC	According EN 61326:2006

Output signals



Signal wiring	Signal name	10V	Cable color	Connector pin no.
	R1K			
+Vin		Excitation + +	White	1
GND		Excitation GND	Brown	2
+Vout		Signal +	Green	3
		Signal GND	Yellow	4

Connection

View to sensor
connector

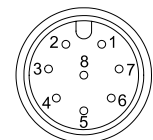

CONN-M12-8F

POSIWIRE®

420A and 420T

Analog Output

Signal conditioner 420A Current output (2 wire)	Excitation voltage	12 ... 27 V DC non stabilized, measured at the sensor terminals
	Excitation current	35 mA max.
	Output current	4 ... 20 mA equivalent for 0 ... 100 % range
	Stability (temperature)	$\pm 100 \times 10^{-6} / ^\circ\text{C}$ f.s.
	Protection	Reversed polarity, short circuit
	Output noise	0.5 mV _{RMS}
	Operating temperature	-20 ... +85 °C
	EMC	According to EN 61326:2006

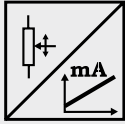

Output signals

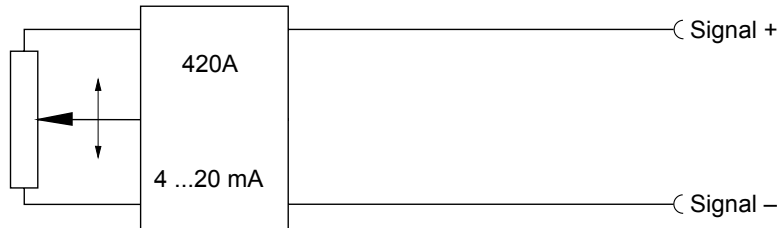

Signal conditioner 420T Current output (3 wire)	Excitation voltage	18 ... 27 V DC non stabilized
	Excitation current	40 mA max.
	Load resistor	350 Ω max.
	Output current	4 ... 20 mA equivalent for 0 ... 100 % range
	Stability (temperature)	$\pm 50 \times 10^{-6} / ^\circ\text{C}$ f.s.
	Protection	Reverse polarity, short circuit
	Output noise	0.5 mV _{RMS}
	Operating temperature	-20 ... +85 °C
	EMC	According to EN 61326:2006

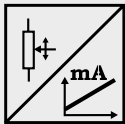

Output signals



Signal wiring	Signal name		Cable color	Connector pin no.
	420A	420T		
Signal +		Excitation +	White	1
Signal -		Excitation GND	Brown	2
		Signal +	Green	3

Connection

View to sensor
connector

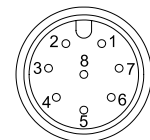

CONN-M12-8F



APPLIED MEASUREMENTS LTD.

3 Mercury House, Calleva Park, Aldermaston, Berkshire, RG7 8PN

Tel: +44 (0) 1189 817339 | Web: www.appmeas.co.uk

Fax: +44 (0) 1189 819121 | Email: info@appmeas.co.uk