

Miniature Low Profile Submersible Tension & Compression **LOAD CELL**

DDEN Series



- Capacities 250N to 50kN
- Tension and Compression
- Sealed to IP68 to 10m depth
- Low Profile and Very Compact
- Integral Male Threads for In-Line Mounting
- Low Deflection
- High Natural Frequency
- Robust Construction
- 3 YEAR WARRANTY

Options Available

Non-Standard capacities & sizes on request
Integral ICA Series Signal Conditioning Amplifier
Shunt Calibration Facility
Spherical Seating Rod End Bearings
Female Adaptors available on request
Compression Fittings available on request

DESCRIPTION

The DDEN range of submersible low profile load cells is designed for the measurement of tensile or compressive forces in underwater locations and in situations where very high humidity or occasional submersion due to flooding is likely.

The DDEN's compact design proves to be advantageous by enabling in-line mounting of the load cell in a wide variety of applications where conventional load cells such as S-Beams will not fit.

The low deflection and high natural frequency of the DDEN offers particular benefits in material testing and cable tension monitoring applications.

The DDEN, as with all other Applied Measurements sensors, can be supplied complete with monitoring/control electronics and calibrated as a system (please refer to the instrumentation datasheets).

A version fitted with an integral amplifier is also available. Designated as the DDENA, it can incorporate any of the ICA series amplifiers to provide a conditioned voltage or current output signal.

Transducer Specialists...

APPLIED MEASUREMENTS LIMITED

3 MERCURY HOUSE - CALLEVA PARK - ALDERMASTON - BERKSHIRE - RG7 8PN - UK

Tel: (+44) 0118 981 7339 Fax: (+44) 0118 981 9121 email: info@appmeas.co.uk Internet: www.appmeas.co.uk



SPECIFICATION

Wiring Schematic Diagram

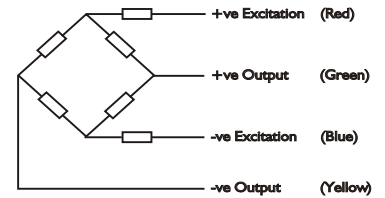

CHARACTERISTICS	DDEN	UNITS
Rated Capacities:	250, 500, 1000, 2000, 5000, 10k, 20k, 50k	N
Rated Output (nominal):	2 (0.75 on 250N & 1.5 on 500N)	mV/V
Non-Linearity:	<0.25	±% of Rated Output
Hysteresis:	<0.30	% of Rated Output
Zero Balance:	<1.0	±% of Rated Output
Temperature Range Operating:	-20 to +80	°C
Compensated:	0 to +70	°C
Temperature Effect On Output:	<0.005	±% of Applied Load/ °C
On Zero:	<0.005	±% of Rated Output/ °C
Safe Overload:	150	% of Rated Capacity
Ultimate Overload:	200	% of Rated Capacity
Excitation Recommended:	10	Volts AC or DC
Maximum:	15	Volts AC or DC
Input Impedance:	700	Ohms
Output Impedance:	700	Ohms
Insulation Impedance:	>500	Megaohms
Construction:	17-4 PH Stainless Steel	
Environmental Protection:	IP68 to 10m depth (please consult sales for greater depths)	
Cable:	2 Metre 4 Core Screened PUR	

Note: Pressure effect on output will be 9N/mH₂O nominal

All dimensions in mm

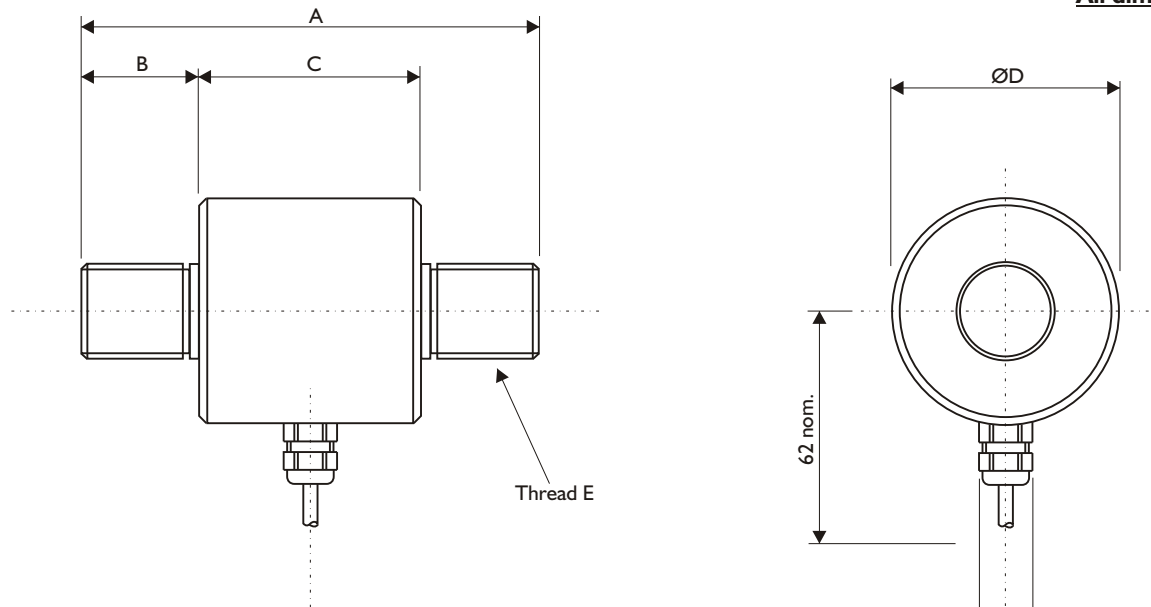

DDEN	A	B	C	ØD	E
250N to 20kN	65	15	35	44	M12x1.75
50kN	71	18	35	44	M16x2.0
DDENA					
250N to 20kN	65	15	35	44	M12x1.75
50kN	71	17	37	51	M16x2.0

