

Low Profile Stainless Steel & Alloy Steel Shear Beam **LOAD CELL**

OSB Series

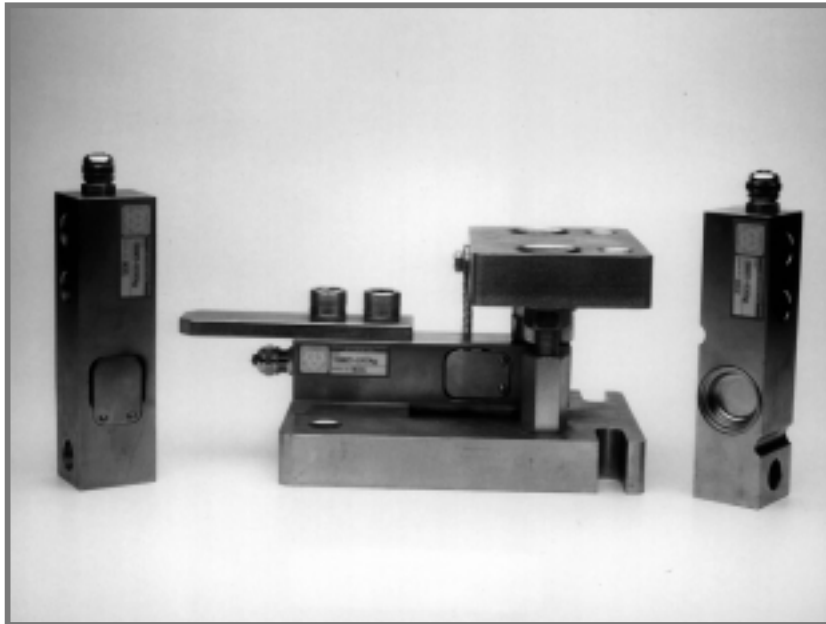

- Capacities 250kg to 5000kg
- Sealed to IP67 or IP68
- Robust Construction
- Sense wire facility
- **3 YEAR WARRANTY**

Options Available

Different Cable Lengths

Full range of mounting options available, including:-

- Vessel/Tank mounting assembly
- Shock/Anti-Vibration mounting assembly
- Platform mounting assembly
- Load Button
- Base mounting spacer
- Spherical rod-end bearings

500VAC Certification

BASEEFA Certification

Low Cost Versions Available

DESCRIPTION

Series OSB are a range of low profile shear beam load cells manufactured from stainless steel (OSBST) or alloy steel (OSBKT). Hermetically sealed against ingress of liquids the sensor's construction and polyurethane shielded cable enables it to function in harsh environments whilst maintaining its integrity.

The low profile, high accuracy and sealing makes this load cell ideal for applications such as low profile platforms, weighing & packing machines and conversion of mechanical scales. The stainless steel construction of the OSBST makes it highly suited for weighing applications such as food, pharmaceutical, brewing, or any application where the load cell needs to be washed down for hygienic purposes.

Sense wires allow the voltage reaching the load cell to be monitored, giving compensation for changes in the lead resistance due to temperature change and/or cable extension and is achieved by feeding this voltage into the appropriate electronics (please refer to the Instrumentation datasheets).

Transducer Specialists...

APPLIED MEASUREMENTS LIMITED

3 MERCURY HOUSE - CALLEVA PARK - ALDERMASTON - BERKSHIRE - RG7 8PN - UK

Tel: (+44) 0118 981 7339 Fax: (+44) 0118 981 9121 email: info@appmeas.co.uk Internet: www.appmeas.co.uk



SPECIFICATION

Wiring Schematic Diagram

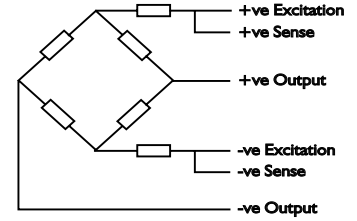

CHARACTERISTICS	OSBKT	OSBST	UNITS
Rated Capacities:	250, 500, 1000, 2000	500, 1000, 2000, 5000	kg
Rated Output:	2.0 ±0.1%	2.0 ±0.1%	mV/V
Accuracy:	<0.025	<0.030	±% of Rated Capacity
Zero Return after 30 mins.:	<0.025	<0.025	±% of Rated Capacity
Zero Balance:	<2.0	2.0	±% of Rated Output
Temperature Range Operating:	-30 to +80	-30 to +80	°C
Compensated:	-10 to +40	-10 to +40	°C
Temperature Effect On Output:	<0.0010	<0.0014	±% of Applied Load/°C
On Zero:	<0.0035	<0.0035	±% of Rated Output/°C
Safe Overload:	150	150	% of Rated Capacity
Ultimate Overload:	300	300	% of Rated Capacity
Excitation Recommended:	10	10	VAC or VDC
Maximum:	15	15	VAC or VDC
Input Impedance:	380 ± 10	420 ± 20	Ohms
Output Impedance:	350 ± 3	350 ± 3	Ohms
Insulation Impedance:	> 1000	> 1000	Megaohms
Deflection at Rated Load:	<0.4	<0.4	mm
Weight:	0.9 (250kg, 500kg & 1000kg) 1.1 (2000kg) 2.1 (5000kg)	0.9 (500kg, 1000kg & 2000kg) 1.9 (5000kg)	kg
Construction:	Nickel Plated Alloy Steel	Stainless Steel	
Environmental Protection:	IP67	IP68	
Cable:	5 Metre 6 Core Screened	5 Metre 6 Core Screened	

OSBKT Outline Drawing

All dimensions in mm

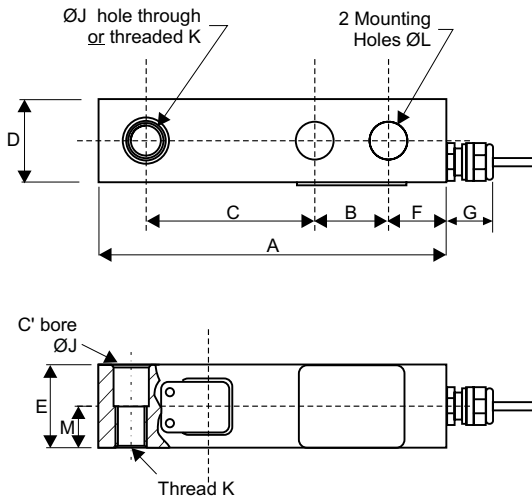

OSBST Outline Drawing

All dimensions in mm

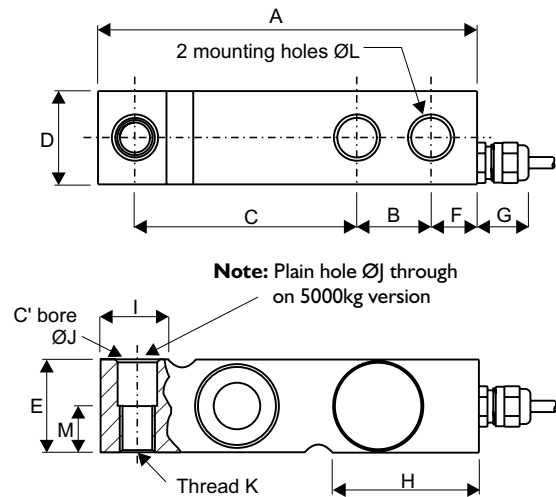

MODEL	RANGE (kg)	A	B	C	D	E	F	G	H	I	ØJ	K	ØL	M
OSBKT	250, 500, 1000	130	25.4	76.2	30.5	30.5	16	19	-	-	13.5	M12 x 1.75	13.5	16
OSBKT	2000	130	25.4	76.2	30.5	36	16	19	-	-	13.5	M12 x 1.75	13.5	16
OSBST	500, 1000, 2000	130	25.4	76.2	32	32	15.8	18	50.5	23.5	13.5	M12 x 1.75	13.5	16
OSBST	5000	171.5	38.1	95.25	36.5	48	19	18	70	37	20.5	M20 x 2.5	20.5	-

