

Static/Reaction
Flange Mounting

TORQUE SENSOR

DTD-F
Series

DESCRIPTION

The DTD-F series of Static/Reaction Torque Sensors have been designed specifically for the measurement of direct torque, and is particularly suited to Fatigue applications. All ranges are constructed from stainless steel and are environmentally protected to IP65.

The sensor is provided with an integral, robust bayonet lemo connector for quick and easy connection purposes.

Other styles and ranges are available and can be designed specifically to meet a particular applications requirement (please consult our Applications Department).

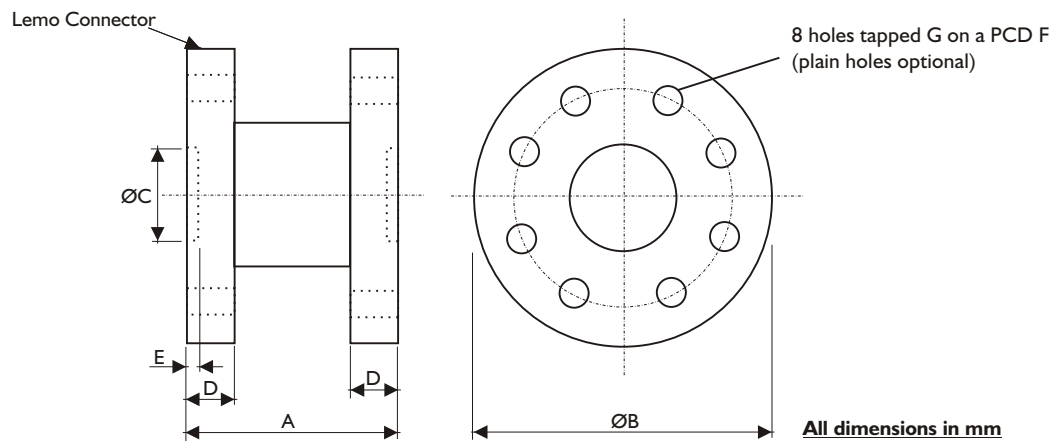

RANGE (Nm)	A	ØB	ØC	D	E	ØF	G
10	76	100	38.1	13	2	82.5	M8
20	76	100	38.1	13	2	82.5	M8
50	76	100	38.1	13	2	82.5	M8
100	76	100	38.1	13	2	82.5	M8
200	76	100	38.1	13	3	82.5	M8
500	76	100	38.1	13	3	82.5	M8
1000	90	125	50.1	19	6	108	M10
2000	90	125	50.1	19	6	108	M10
3000	120	150	50.1	35	6	108	M16
5000	120	205	80.1	38	8	165	M16
10000	190	205	80.1	38	8	165	M16
20000	216	250	102	32	8	203	M20
30000	226	355	152	50	8	280	M24
50000	226	355	152	50	8	280	M24

CHARACTERISTICS	DTD-F	UNITS
Range:	10, 20, 50, 100, 200, 500, 1000, 2K, 3K, 5K, 10K, 20K, 30K, 50K	Nm
Excitation Voltage:	10 (15 Max.)	VDC or VAC
Sensitivity:	2.0 (up to 10K) or 1.5 (20K and above)	mV/V (Nominal)
Overload Protection:	150	±%FSO
Non-Linearity:	<0.25	±%FSO
Repeatability:	<0.05	±%FSO
Hysteresis:	<0.10	%FSO
Temperature Range	Operating: 0 to +80	°C
	Compensated: +20 to +60	°C
Temperature Effects	On Zero: <0.010	±%FSO/°C
	On Output: <0.020	±Reading/°C
Bridge Resistance:	700 nominal	ohms
Fatigue Rating:	20 million fully reversed cycles	
Environmental Protection:	IP65	

Transducer Specialists...

APPLIED MEASUREMENTS LIMITED

Issue 04/09



3 MERCURY HOUSE - CALLEVA PARK - ALDERMASTON - BERKSHIRE - RG7 8PN - UK

Tel: (+44) 0118 981 7339 Fax: (+44) 0118 981 9121 email: info@appmeas.co.uk Internet: www.appmeas.co.uk