

# Brushless Rotary Keyed Shaft **TORQUE SENSOR**

YDSA  
Series



- Torque Ranges 0.2Nm to 50Nm
- 0.2% Accuracy Class
- Suitable for low capacity
- High RPM capability
- 3 YEAR WARRANTY

#### Options Available

Mounting pedestal

Customer-specific measuring ranges

Supplied With Any Instrumentation and Calibrated as a Complete System with Traceable Certificate

## **DESCRIPTION**

The YDSA torque sensors are a slip ring miniature sensor designed for low load applications. They feature high accuracy and high speed and require minimal mounting space due to their compact size.

The YDSA series can be further complimented by any of our range of instrumentation to offer a complete system, supplied and calibrated from a single supplier.

*Transducer Specialists...*

## **APPLIED MEASUREMENTS LIMITED**

3 MERCURY HOUSE - CALLEVA PARK - ALDERMASTON - BERKSHIRE - RG7 8PN - UK

Tel: (+44) 0118 981 7339 Fax: (+44) 0118 981 9121 email: [info@appmeas.co.uk](mailto:info@appmeas.co.uk) Internet: [www.appmeas.co.uk](http://www.appmeas.co.uk)



# SPECIFICATION

CHARACTERISTICS	YDSA	UNITS
<b>Torque Ranges:</b>	<b>0.2 - 50</b>	<b>Nm</b>
<b>Rated Output (FSO):</b>	<b>1.3</b>	<b>mV/V</b>
<b>Excitation Voltage:</b>	<b>10</b>	<b>VDC</b>
<b>Safe Overload:</b>	<b>150</b>	<b>% FSO</b>
<b>Non-Linearity:</b>	<b>0.2</b>	<b>±% FSO</b>
<b>Repeatability:</b>	<b>0.1</b>	<b>±% FSO</b>
<b>Hysteresis:</b>	<b>0.2</b>	<b>% FSO</b>
<b>Temperature Range Compensated:</b>	<b>-10 to -60</b>	<b>°C</b>
<b>Operating:</b>	<b>-20 to -70</b>	<b>°C</b>
<b>Temperature Effect on zero:</b>	<b>0.005</b>	<b>±%FSO/°C</b>
<b>Temperature Effect on Output</b>	<b>0.009</b>	<b>±%FSO/°C</b>
<b>Terminal Resistance (Input/Output)</b>	<b>350±5</b>	<b>Ohms</b>
<b>Insulation Resistance:e</b>	<b>300</b>	<b>Megaohms at 500VDC</b>
<b>Environmental Protection:</b>	<b>IP 50</b>	
<b>Cable:</b>	<b>3 screened Ø4mm</b>	

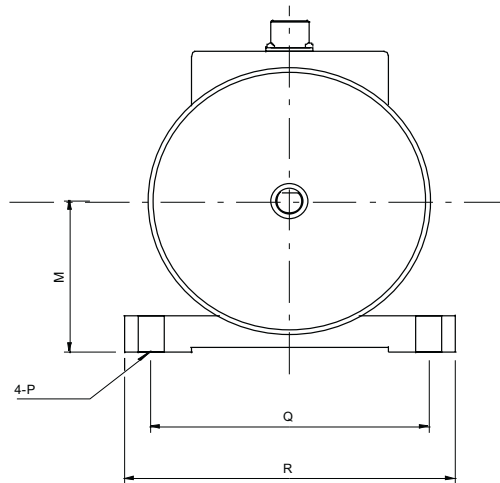
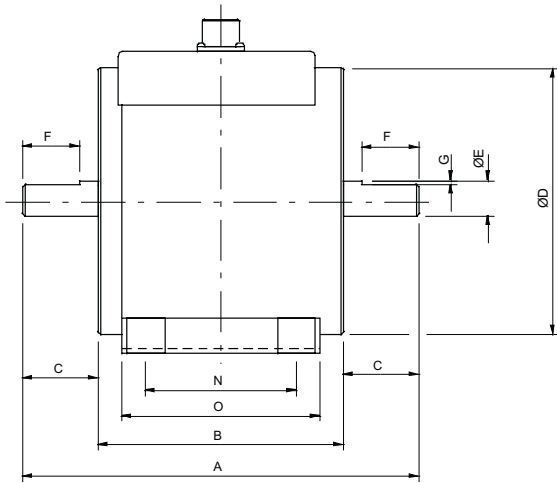

CAPACITY	A	B	C	ØD	ØE	F	G	M	N	O	ØP	Q	R	RPM
0.2-2	84	52	16	60	8	12	1	34.0	32	42	5.5	59	70	8.000
3-5Nm	88	56	16	60	12	12	1	34.0	32	42	5.5	59	70	8.000
10-30NM	90	58	16	72	18	12	5x5	40.5	32	46	6.5	72	86	8.000
50NM	118	58	30	72	18	26	5X5	40.5	32	46	6.5	72	86	8.000

