



Datasheet

Torque Sensor, waterproof

DRWPL

Torque ranges from 0,1 Nm to 1500 Nm
waterproof IP67
with angle and speed measurement

Features

- waterproof IP 67
- contactless
- integral torque amplifier
- single supply voltage
- wide range of applications
- small form
- low moment of inertia
- speed measurement (option)
- angle measurement (option)

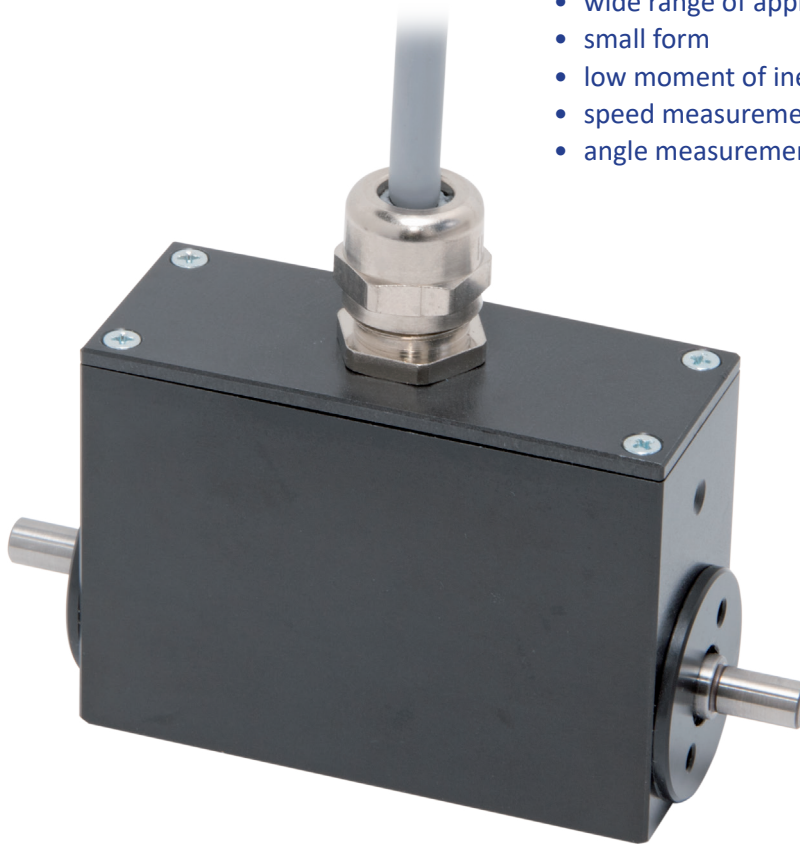

DRWPL series torque sensors are fitted with a number of gaskets in compliance with international protection IP 67.

The devices are also available with optional speed or angle detection for a host of applications. The integrated signal amplifier is powered with 12 V DC and outputs an electrically isolated analog signal of 0 to ± 10 V.

Technical Specifications DRWPL

Supply voltage:	12 V DC \pm 10 %
Power consumption:	approx. 200 mA
Rise time 10-90 %:	2 ms
Limit frequency -3 dB:	200 Hz (optional 1 kHz)
Voltage output:	0 to \pm 10 V
Internal resistance:	100 Ω
Ripple:	< 100 mVpp
Nonlinearity/max. measurement error (of full scale):	0,1 %
Hysteresis:	0,1 %
Deviation at zero point:	$\leq \pm$ 100 mV
Max. measurement error:	0,1 % (FS / of full scale)
Operating temperature:	0 - 60 °C
Compensated temperature range:	5 - 45 °C
Temperature error	
Zero point:	0,02 % / K
Sensitivity:	0,01 % / K
Mechanical overload:	100 %
Internal protection:	IP67
Cable length:	2,5 m (standard)
Connection:	flying leads
Factory calibration right-/ left load in 25% steps. Special calibration on request.	
EMV Immunity for interference (DIN EN 50082-2) *1	
Enclosure	Severity
HF line interference	
150 kHz - 80 MHz (AM)	10 V
ESD (Electrostatic discharge)	Air 8 kV / Kontakt 4 kV
Enclosure	
Electromagnetic field	
80 Mhz - 1000 MHz (AM)	10 V/m
150 kHz - 80 MHz (AM)	20 V/m
Leads - Connection Cable	
Burst (fast transients)	2 kV
*1 Severity / criterion: industrial environment; Cable length \leq 30 m. Application not outside buildings.	
Interference Emission (EN 55011)	
Disturbance Voltage (electromagnetic disturbances)	Class B (150 kHz - 30 MHz)
Radiated Emission (electromagnetic disruption axis)	Class B (30 MHz - 1000 MHz)

Speed Option (n)	
max. rev.:	up to 10 000 min ⁻¹ *2
Output:	open-collector
Internal pull up:	10 k Ω (5 V level)
External pull up:	24 V max . / 20 mA
Pulses / rev.:	60
*2 with suitable external wiring 20.000 min ⁻¹ (or speed max.)	

Angle Option (w)	
max. rev.:	up to 3 000 min ⁻¹ *3
Output:	open-collector
Internal pull up:	10 k Ω (5 V level)
External pull up:	24 V max
Pulses / rev.:	360
Resolution:	1°
Phase shift	Channel A 90° at right spin of propulsion side.
*3 with suitable external wiring 15.000 min ⁻¹ (or speed max.)	

Mechanical Dimensions DRWPL

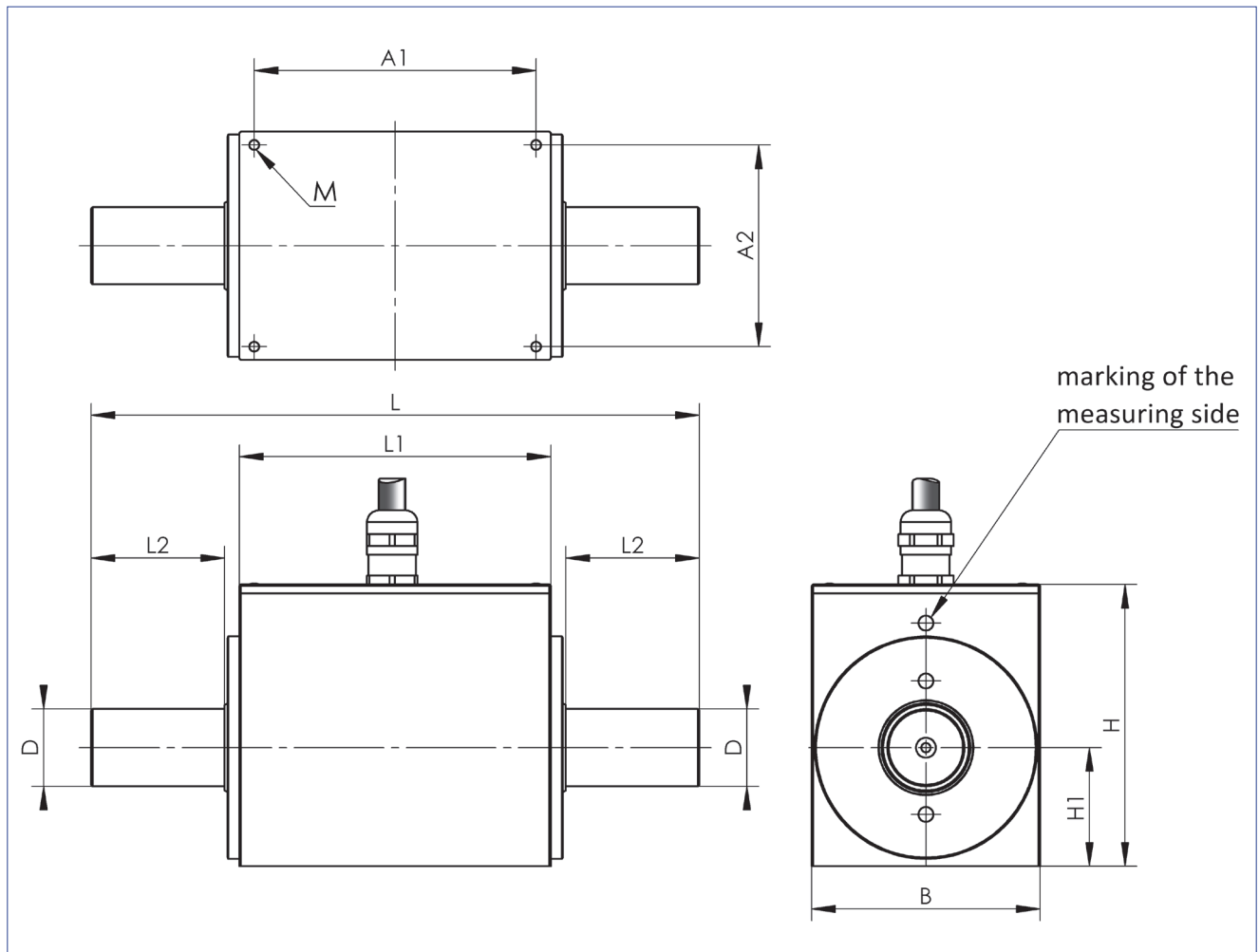

	DRWPL-I	DRWPL-II	DRWPL-III	DRWPL-IV
Torque range	0,1 0,2 0,5 1 2	5 10 20 50	50 100 200 300	500 1000 1500
L (mm)	103	160	205	310
L1 (mm)	74	92	105	126
L2 (mm)	11	30	45	85
B (mm)	30	50	77	120
H (mm)	53	68	95	112
H1 (mm)	15	25	40	52
D g6 (Ø mm)	6	15	26	45
A1 (mm)	68	82	95	105
A2 (mm)	24	40	68	105
M	M3 x 5 deep	M4 x 8 deep	M4 x 8 deep	M6 x 10 deep
Weight approx. (g)	280	920	4925	8000
Speed max. (1/min)	20.000	10.000	5000	1900

General tolerances DIN 2768-m

Technical Specifications DRWPL

Sizes	Torque Range (Nm)	Spring Constant C (Nm/rad)	Mass Moment of Inertia J (g•cm ²)			Rated Axial Load (N) *	Rated Radial Load (N) *
			Total	Drive Side	Measuring Side		
I	0,1	33	7,7	6,8	0,9	140	1,5
	0,2	33	7,7	6,8	0,9	140	1,5
	0,5	86	7,9	6,9	0,8	160	2
	1	86	7,9	6,9	0,8	210	3,5
	2	173	7,9	7,0	1,0	210	6,5
II	5	936	111	77	34	930	10
	10	2017	111	78	33	930	20
	20	3626	112	78	34	930	50
	50	5808	116	80	36	930	110
III	50	15.471	984	560	424	1820	60
	100	25.696	993	564	429	1820	130
	200	41.762	1020	578	442	1820	250
	300	48.872	1047	591	456	1820	380
IV	500	205.695	11.778	6455	5323	4160	522
	1000	290.236	12.011	6572	5439	4160	1019
	1500	327.886	12.277	6705	5572	4160	1502

*The values for axial and radial load apply to the non-fixed housing

Ordering Code

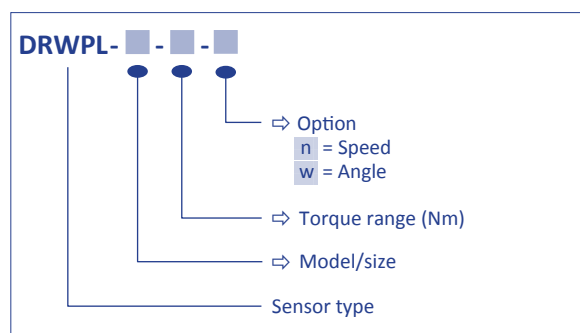

Available Accessories

Supply and display unit: ValueMasterBase
Couplings